

HDMI-19P-SND12x-S297

SHELL PLATED :

Blank	NI
G	GOLD

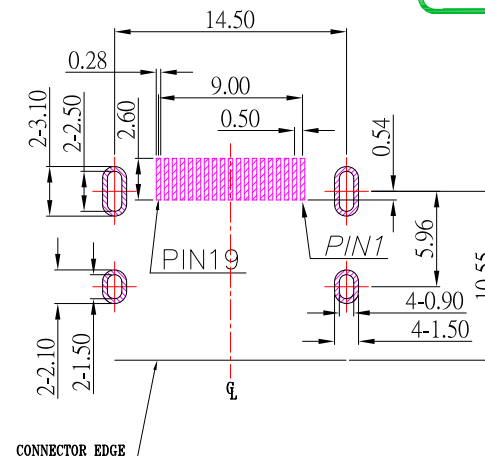

RECOMMENDED P.C.B. LAYOUT

NOTE:

1.MATERIAL:

- 1.1 HOUSING: LCP,UL94V-0 , BLACK
- 1.2 CONTACT: BRASS
- 1.3 SHEEL: BRASS

2.PLATING :

- 2.1 CONTACT: PLATED GOLD IN MATING AREA ;
TIN PLATED ON SOLDER BALLS ;
NICKEL UNDER PLATED OVERALL
- 2.2 SHELL: NICKEL UNDER PLATED SURFACE LAYER

3.ELECTRICAL:

- 3.1 RATING: 40V , 0.5A
- 3.2 INSULATION RESISTANCE: 100MΩ MIN
- 3.3 CONTACT RESISTANCE: 30 mΩ MAX
- 3.4 WITHSTANDING VOLTAGE: 500V AC / MINUTE
- 3.5 OPERATING TEMPERATURE: -25°C~ 85°C

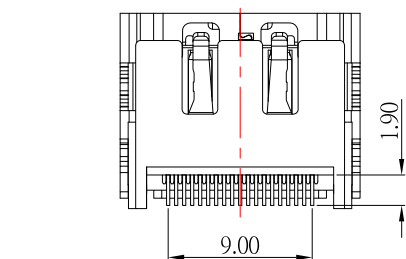
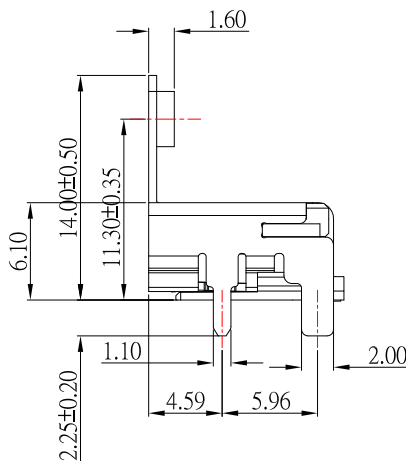
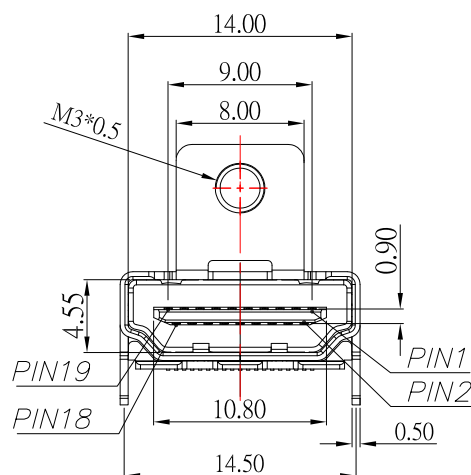

東莞市高迪電子有限公司
DONG GUAN GAO DI ELECTRONICS CO., LTD

TOLERANCE UNLESS OTHERWISE STATED :

Up to 5 ±0.2
Above 5 ~ 15 ±0.3
Above 15 ~ 30 ±0.4
Above 30 ~ 50 ±0.5
Angle ±0.3°

3RD. ANGEL'S



UNITS MM

DRAWN BY:	DATE
Jack Lu	02/02/23
CHECKED BY:	DATE
Jacky Chen	02/02/23
APPROVED BY:	DATE
Tony Kao	02/02/23

MAT'L		TITLE	CONNECTOR
FINISH		MODLE	HDMI AF SMT 單耳無柱,螺絲孔 H11.30mm
SCALE	1 : 1	DWG NO.	HDMI-19P-SND12x-S297
SHEET NO.	1 of 1	PART NO.	HDMI-19P-SND12x-S297
		SIZE	A4
		VER	R2

2	更新MODLE描述	Jack	020223
1	更新圖面	Jack	052020
ITEM NO.	DESCRIPTION	DRAWN	DATE